



Article History: Received: 27 Aug 2021 | Revised: 10 April 2022 | Accepted: 22 April 2022

Original Article

Gandhian Spherons: India/Nepal Return to the Varnas Peace World Leadership



Bishnu Pathak*
Kathmandu, Nepal
*Corresponding
Author.
Email:
ciedpnp@gmail.com



Mairead Corrigan
Maguire
(1976 Nobel Peace
Prize Laureate)
Peace People, United
Kingdom
Email:
mairead@peacepeople.com



John Scales Avery
(1995 Nobel Peace
Prize Laureate)
The University of
Copenhagen,
Denmark, Copenhagen
Email:
avery.john.s@gmail.com

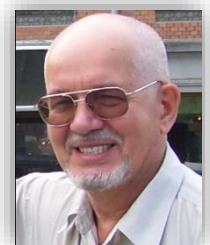

Mikhailovich Leo
Semashko
Gandhian Global
Harmony Association,
St. Petersburg, Russia
Email:
leo.semashko@gmail.com



© 2022 The Author(s). This open access article is distributed under the terms of the Creative Commons Attribution-NonCommercial-ShareAlike (CC-BY-NC-SA) International Public License (<https://creativecommons.org/licenses/by-nc-sa/4.0/>), which permits non-commercial re-use, distribution, and reproduction in any medium or format, provided the original work is properly cited and such creations are licensed under the identical terms.

Abstract

The article summarizes 16 years of research by the Gandhian Global Harmony Association's humanities scientists in the field of the genetic thermodynamic cybernetic social structure of nonviolence spherons and its empirical verification by world statistics. The article context narration is undertaken in the logic of theoretical knowledge, in the cognitive movement from the whole, general and abstract to the parts, single and concrete. This logic is accompanied and illustrated by a visual series of systemic structural modeling. The research of spherons as a deep invariant social structure that constitutes the genetic fundamental substance of any society in the corresponding innovative sociocybernetic science qualitatively changes the general traditional vision of society and raises its knowledge to the level of natural sciences with fundamentally new digital technologies in all its spheres. This qualitatively innovative science with Einstein's "substantially new manner of thinking" based on the invariant genetic structure of spherons provides a single scientific, acceptable to all peoples, nonviolent solution of the civilizational confrontational crisis that began in 1914, since the WWI and continues to this day, together with all its aggravating and insoluble for traditional thinking global challenges, pathologies and pandemics. Only conscious, enlightened spherons are able to lead humanity out of the deadly dead end of more than a century global confrontation into the space of global convergence, sustainable development, solidarity and partnership. To continue and intensify these fundamental innovative scientific researches, it is proposed to create an independent International Humanitarian Academy of Spherons, for a start, from 20-30 humanities scientists, mathematicians, cyberneticians, statisticians and programmers in any country that agrees to finance it and which will pay for itself in 3-4 years.

Keywords: *Spherical approach, spherons, social structure, noosphere, nonviolence, peace, confrontation, nuclear war, geopolitics, ecology, GlobStat*

Asymmetric Alternative to Suicidal Military Geopolitical Confrontation

The significant problems we face cannot be solved at the same level of thinking we were at when we created them. [Therefore, their solution] requires a substantially new [nonviolent, asymmetric] manner of thinking if mankind is to survive. - Albert Einstein

It is simply impossible to liquidate a confrontation by thinking like everyone else.

The whole world 75 years after the end of the WWII and the atomic bombings of Hiroshima and Nagasaki has been witnessing the accelerating avalanche of interstate military geopolitical confrontation and the pace of preparation for the genocidal third world nuclear war, the last for humanity. There is more than enough evidence of this: NATO's nuclear fence on the western border of nuclear Russia, a trillion dollars to upgrade America's nuclear potential by 2030, £ 41 billion to expand Britain's nuclear arsenal by 40%, the NATO's 2021 declaration of Russia and China as strategic enemies for all foreseeable future, etc. The deadly global trend that has been growing like an avalanche for

75 years confirms the *Kennedy-Eisenhower law* on the mortal danger of the military-industrial complex and the war prepared by it, which will put an end to humanity if humanity does not put an end to the war. Humanity during 75 years is not able to not only put an end to it but also even to start looking for it and to launch scientific research in this direction (Avery, 2017a; Maguire et al., 2018). The governments have increased military spending dozens of times for this time, but have not found a penny for the innovative socio-humanitarian science of nonviolence and peace.

Our article, reflecting the results of more than 45 years of scientific research on the invariant global social structure of the nonviolence spherons, offers their sociocybernetic and thermodynamic theory as a working hypothesis for explaining, understanding and managing the still unknown "*greatest force of nonviolence*" of the Mahatma Gandhi varnas-spherons (Gandhi, 2005, 1955) as an asymmetric alternative to the suicidal military-political confrontation. The first step and task of this hypothesis is to provide, first for civil society, and then for states, a theoretical neutral basis, acceptable to all "hook", to overcome confrontation in geopolitical science.

The next, second step is the transition to the creation, based on the tested theoretical hypothesis of spherons, of the International Humanitarian Academy of Spherons (IHAS) with the participation of humanitarians from all nuclear powers, so that it can prepare a scientifically based project of the "*Global Security/Peace*". This project would create a scientific platform for overcoming state military-political confrontation and the transition to a joint, partner and nonviolent geopolitical construction of a world order without weapons, primarily without nuclear weapons. A similar project, as a first approximation, is proposed in our book "*Anti-Nuclear Manifesto*" by 46 coauthors, including 4 Nobel laureates, from 26 countries, which was presented to all national missions of UN member states at the end of 2020 (Semashko et al., 2020).

In the scientific support of similar transition from confrontation to cooperation on the basis of an internationally proven working hypothesis of the spherons social structure, we, this article international humanitarians authors, responsible representatives of the world civil society, see our highest moral duty and the vocation of scientists in the face of the

steadily growing threat of global nuclear genocide (Avery, 2017a). This is the first and only theoretical scientific hypothesis for overcoming global confrontation in 75 years, which offers world humanitarian scientists, primarily USA and Russia, which possess 96% of the nuclear arsenal, to begin scientific research, verification and development of Mahatma Gandhi's law. He formulated it almost a century ago, that "nonviolence [of the spherons] is the greatest force of humanity, [which] is mightier than the mightiest [nuclear] weapon of destruction" (Gandhi, 2005, 1955). Why shouldn't responsible humanitarian scientists, first of all America and Russia, investigate this "greatest force of humanity" in order to use it for the common good, for liberation from the deadly threat of nuclear suicide, for prosperity and sustainable development in the global world (Avery, 2017a; Maguire et al., 2018)? Our article is devoted to the answer to this question, behind which is the experience of research and scientific searches for more than 45 years.

It is especially important in our time, when even government hawks are beginning to realize the hopelessness of militarism in promoting democracy, as US Secretary of State Anthony Blinken

recently made a truly sensational statement: “We will not promote democracy through costly military interventions or attempts to overthrow authoritarian regimes by force. We have tried this tactic in the past. As good as the intentions were, they didn’t work.” If this is so, then only the path of nonviolent positive examples and searches in the field of democracy remains (Lozansky, 2021).

If this proposal to create a neutral Humanitarian Academy (or Laboratory) for a joint scientific, statistical research of the nonviolence spherons constituting, according to Gandhi, the "*Newtonian law of all humanity*" will be rejected, then all of us will have no choice but to urge all people to dig earth bunkers-crypts for themselves and their children. No other chance out of 100% probability of suicidal nuclear war not remains. It has remained zero for the past 75 years and now remains zero, with no signs for the future.

Necessary and Sufficient Resources-Components of Society as a Whole:

People, Information, Organization, Things

The question of the fundamental pillars, sources, resources and components of society has always interested thinkers throughout the written history and received one or another answer from them. In the summarizing article, there is no opportunity and need to at least somehow state it, since it is presented in numerous works, including the works of the author and his colleagues, the key ones of which are indicated in the bibliography.

The result of a thousand-year search in this direction is the conclusion about four invariant, necessary and sufficient social resources of the life of society and the individual at all levels of humanity/noosphere: People, Information, Organization, Things, in short (PIOT). This abbreviation is linguistically similar to the abbreviations R. Park: POET (1952), T. Parsons: AGIL (1977) and the like. According to all PIOT, society is an open system both with the external natural environment and with all levels of society within itself. Any of his closeness to any of PIOT is fatal for it.

In the history of sociology, PIOT was clearly recognized as components of society by Bukharin (1922), Kondratyev (1930), Bertalanffy (1962), and Toffler (1980), perhaps others, but we do not know them. Many other sociologists, philosophers, historians: Plato, Aristotle, Comte, Weber, Durkheim, Habermas, Luhmann, Jaspers, Braudel, Kovalevsky, Sorokin, Giddens, Park, Znaniecki, Giddens, Sztompka, Castells and others to one degree or another approached this idea within the framework of very different paradigms, primarily pluralistic. For an analysis of the history of these above-mentioned tetradic ideas of PIOT, see the university textbook "Sociology for Pragmatists" (Semashko, 1999).

PIOT are structurally invariant, necessary, sufficient, coherent and mutually include each other according to the Anaxagoras principle "everything in everything", which expresses their fractal relation as "matryoshka dolls", as the participation of "everyone in each", but with the priority of one of them, that defines the qualitative specifics of each of them. The similar ontological features of PIOT resources serves as an epistemological reason for the difficulties of their cognition and errors in their classification. Dialectics of PIOT

unity and harmony as opposites, their similarities and differences, in which their "struggle" is only a particular moment of their harmony are revealed here (Semashko, 1999, pp. 183-200).

In structural modeling (Bentler, 2010), the following model expresses the necessary and sufficient resources/components of society PIOT in static:

Model-1: The Society Resources / Components of PIOT

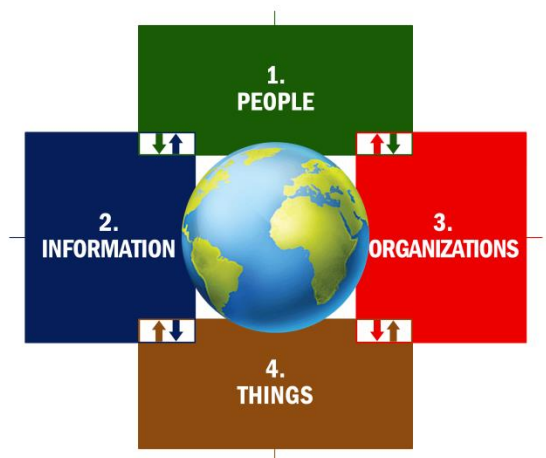

PIOT make up the static components of society, which in dynamics act, on the one hand, as necessary and sufficient resources for its continuous reproduction or social autopoiesis (Maturana & Varela, 1980; Luhmann, 2007), and, on the other hand, as products/results of its

previous cycle. They, in turn, become resources for a new cycle of production/autopoiesis, which repeats endlessly and continuously in the history of all human societies and humanity as a whole. Any community of people, starting with the family, represents in statics a synergistic sum of PIOT resources / components and nothing else at the social level, which relies on the biosphere and is connected by an inseparable umbilical cord with the entire natural, organic and inorganic world. This is the structural law of all societies and communities.

PIOT resources are empirically evident at the superficial level, but as a whole they are invisible and require theoretical definition in statics, outside of motion. In the center of model-1, which concentrates all the infinite cultural and historical diversity of PIOT, one can imagine any social object from an individual, family, club, school, company to a country, humanity and the noosphere as a whole, for which PIOT are always their constituent components and at the same time - necessary and sufficient resources for their continuous life. A theoretical proof of the PIOT substance for all societies requires the formulation of appropriate definitions and laws.

Definitions and Laws of PIOT Social Components

1. **People (P)** - the totality, community, cluster of all human individuals from birth to death. It is the first and only resource of society, producing all social resources, including itself. A zero of people is a zero of society that expresses its highest existential law of the absolute social necessity of people.

1.1. **The population** is people differing in territory/place of residence: planet, continent, country, city, house, apartment, any other place where people live.

1.2. **The nation (the people)** is people differing in national and ethno cultural characteristics.

1.3. **Spherons** are four extremely large and invariant clusters/groups of people throughout human history, which include the entire population, without exception, in all social objects from the family to the noosphere and which differ only in employment in four spheres of social production / autopoiesis. Spherons are Divine, eternal, social structure of people / nations / population, their generic, genetic, peaceful and harmonious substance. Spherons are

creators, actors and saviors of humanity. They are discussed in more detail below.

1.4. **Spherons** at the global level of the noosphere and humanity are called "**noospherons**".

1.5. **Partons** are specific groups of people that are historically transient parts of spherons at every stage of human evolution, which differ in a variety of demographic, branch, professional, economic, political, national, cultural, religious and other foundations. Partons are temporarily existing, empirically recorded manifestations and expressions of spherons in real time, without which spherons, as their essences, do not exist in their pure form. Partons are partial and blind class forms of spherons, usually at enmity or war with each other for property and power. The nuclear partons are blind eco/geno/suicides, suicide bombers of humanity and the planet.

Structural realities of spherons and partons are mutually complementary and dialectically inseparable. They are separated only in knowledge for their true understanding. A detailed research of spheres / spherons and partons in their dialectics is presented in their structural branch tables, proving their absolute universal reality, in the first chapter of

"*Global Peace Science*" (Semashko et al, 2016, pp. 21-50).

2. **Information (I)** in society, social (I) is any knowledge and representation from elementary sensory perception to the highest spiritual values and constructions, both individual and collective at any level and scale, both living and materialized in any media from the brain to all human works. The zero information is the zero of society that expresses its highest existential law of the absolute social necessity of information. (Ashby, 1956; Avery, 2018; Hartley, 1928; Shannon, 1948).

3. **Organization(s) (O)** in society, social (O) is/are the entire cluster of norms, orders, requirements, regulators, tools, institutions, which format, limit, manage, control, guide, govern, regulate and streamline, i.e. organize the whole set of social relations of society/individuals with all PIOT. The zero of the organization is the zero of society that expresses its highest existential law of the absolute social necessity of organization(s).

Pythagoras and his followers identified the eternal law of nature and society with the number "four" organizational structure in the verse 47: "*I swear it by*

him who has transmitted into our souls the Sacred Quaternion, the source of nature, whose cause is eternal.” (Firth, 1904). Therefore, Pythagoras and his thousand-year school almost three thousand years ago chose the "Sacred Quaternion" as a symbol of the Demiurge, world harmony and its measure, including society. The subsequent great thinkers developed the universal harmonious "Quaternion" paradigm: I. Kant (2003), M. Gandhi (1955), A. Poincaré (1913) and others as a common link between nature, society and human.

Social organization comes from the orderliness of the natural processes of solar movement, the change of seasons, the daily rotation of the sun, birth, maturation, fruiting, old age and dying in wildlife, etc. (Prigogine & Stengers, 1984). One of the first who began to study social organization from the natural was A. Bogdanov, who in "Tektology" (1922) considered it in the paradigm of natural balance and harmony, which Marxism rejected for its destruction.

4. **Things (T)** are the entire cluster of all material goods and services of society that do not exist in nature in a finished form, but are created from natural

resources, the remake and use of which in society transforms them into qualitatively special, social things that are absent in nature. The zero of social things is the zero of society that expresses its highest existential law of the absolute social necessity of things.

The origin of social things, the entire aggregate of material goods and services from the natural components of the Earth, Water, Air and Fire/Sun (EWAFF) and biological resources of the planet is obvious to everyone and does not require proof.

All PIOT resources are equally inherent in the absolute necessity and sufficiency for the life of any society/individual. This defines the absolute existential social law of each PIOT and them together. It follows from the decisive thought experiment of the impossibility to imagine the real life of a society/individual in the absence of at least one of PIOT and the impossibility of adding to them any other social resource/component that would not be included (not contained) within the four PIOT resource clusters. Similar thought experiment is available to every intelligent person. Try to imagine the life of any society/individual in the complete absence of at least one of PIOT. It is

impossible to imagine that is confirmed empirically by the whole of human history, which does not know analogic examples.

This is the theoretical and empirical proof of the PIOT necessity and sufficiency absolute existential law for any society and individual, which determines the entire social historical logic, together with all its conclusions and consequences, both in the past and in the present and future.

Necessity and Sufficiency of Four Spheres of Social Production

The necessity and sufficiency of PIOT transforms life, being, existence of a society/individual into a historically continuous, endless functional system of social production or social autopoiesis within the framework of both individual ontogenesis and historical phylogenesis (Luhmann, 2007; Maturana & Varela, 1980) PIOT as its final products, necessary for further use as initial vital resources of PIOT. The law of absolute necessity and sufficiency of PIOT resources determines the law of absolute necessity and sufficiency of the corresponding four spheres of social

production/autopoiesis that reproduce PIOT components.

A functional or dynamic system of social production, combining four PIOT processes: their production, distribution, exchange and consumption (PDEC), is necessarily structured at the genetic level, internally divided into four spheres of production/autopoiesis, the subject and product of which make up the corresponding PIOT. These spheres are as EQUALLY necessary and together sufficient similar as PIOT. The history of cognition has long and painfully gone to understanding and defining these spheres of production through many thinkers of different eras in a variety of philosophical paradigms, discussed in detail in the book (Semashko, 1999). From them, it is necessary to single out Marx (Marx & Engels, 1956), who was the first to define four spheres of production in the "*Feuerbach. German Ideology*" and also Braudel (1988) and Gandhi (1955), whom also firmly distinguished four production spheres. This group of thinkers includes many of their followers in this matter: Kondratyev (1930), Barulin (1982), Braudel (1988), Parsons (2007), Toffler (1980), Castells (2000) and others.

The representation of the four spheres of social production in variable terminology: social (everyday), informational (spiritual, cultural), organizational (political, managerial, governing), technical (material, economic) in the most adequate and frequently used terms are expressed by the following structural model.

Model-2: The Society SIOT Spheres of Production

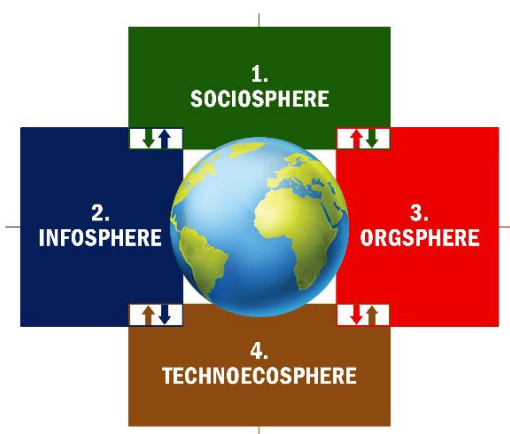

The spheres of social production differ in the final PIOT product/resource that is created and reproduced in it:

- Sociosphere** produces PEOPLE,
- Infosphere** produces INFORMATION,
- Orgosphere** produces ORGANIZATIONS,
- Technoecosphere** produces THINGS.
(Or the **Technosphere**, which unites

economics and ecology, its four natural elements, from which it is inseparable.)

The four spheres of social production are designated shorten by the abbreviation SIOT. All spheres are inseparable, coherent and mutually included, like PIOT resources and PDEC processes, therefore no sphere can exist separately from others, as they all together cannot exist at least without one of them. Therefore, they are equally necessary and together sufficient that excludes the monistic/primordial primacy and absolute determining role of any of them. Each sphere produces its product according to its own unique laws, technologies, special means, methods and tools that are adequate to the specific laws of the PIOT result produced. The SIOT spheres determine the structure of social needs, abilities, employment, labor, property, money, PDEC processes, etc.

Each sphere of SIOT in each historical epoch is filled with the corresponding branches of production that create certain specific historical forms of their products/resources. These forms, as well as the branches corresponding to them, can arise and disappear or fundamentally renew their quality. They can be included in larger branches, becoming

their sub-industries, or, conversely, they can expand into macro-industries. This is an endless and continuous process of aggregation and disaggregation of branches/industries within each sphere, which never leads to the disappearance of the sphere of production with all its sectoral/branch qualitative and quantitative transformations. The branches are variable elements of spheres, and spheres always remain substantially constant, invariant SIOT structures in all societies and in any historical epoch.

The fundamental meaning of spheres and spheral organization at all levels of life from micro to macro as "spaces of coexistence" that are "crucial" for understanding humanity is deeply analyzed by the German philosopher Peter Sloterdijk in his trilogy "Spheres" (1998, 1999, 2004).

Necessity and Sufficiency of Four Spherons Social Structure

The spheres of social production and social life of SIOT cover the entire population, include all people, without exception, from birth to death.

Therefore, the SIOT invariant spheres divide the entire population into four invariant groups, classes, communities, clusters of people, which differ in terms of employment in these spheres. In this regard, the best, most adequate term for them, expressing their generic attribute of spheral employment, is the term "SPHERON(S)". But it does not negate the use of the traditional terms "group, class, community" to denote the belonging and employment of these clusters of people in the SIOT spheres. The aggregate cluster of PEOPLE is divided equally by the necessary and sufficient SIOT spheres into the corresponding, EQUALLY necessary and together sufficient, four SPHERONS, which differ in their final product/resource produced by them, or, that is identical, in their employment in the respective spheres.

*Model-3: Four SPHERONS of Global
Social Production*

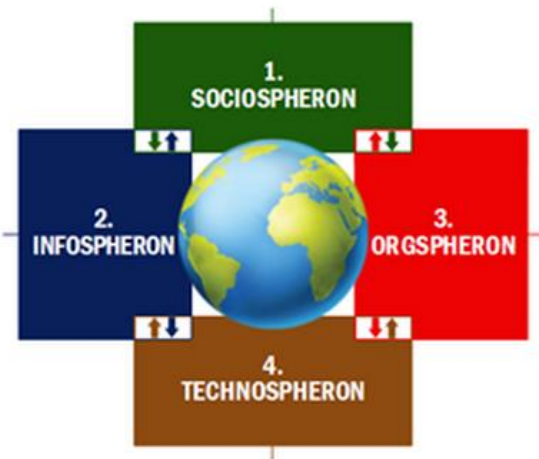

Sociosphere, employed in the production of PEOPLE in the sociosphere,

Infosphere, employed in the production of INFORMATION in the infosphere,

Orgosphere, employed in the production of ORGANIZATIONS in the orgosphere,

Technosphere (or **Technoecosphere**), employed in the production of THINGS in the technosphere.

The spheres abbreviation is the same as the spheres in which they are employed and in which they differ but to distinguish which the term "sphere" is added: SIOT-spheres, or in short: SIOT-s.

The division of people into necessary and sufficient spheres constitutes the absolute, normative, genetic, invariant social structure of ANY society in history at all its levels, without exception. Therefore, in the Model-3 center any variable in history, a social object, from an individual, family and settlement to a city, country and humanity as a whole, can be placed.

SIOT spheres are the only living, energetic actors of PIOT resources, which have not natural, but artificial, social origin in the process of their continuous social production by spheres. Spheres, as actors of social production, differ not in private, secondary to their life and historically transient attributes of property (like in Marx), or stratification, as in empirical sociology (Giddens, 1984, 1998), or others similar, but in general, invariant, absolutely necessary and sufficient spheres of production in which they are engaged. Therefore, they have all the fundamental attributes of these realms/spheres. Therefore, spheres are universal, necessary, sufficient and coherent, like the SIOT spheres in which they are employed. Spheres are inseparable and interdependent, they, like all people, "stand on each other's shoulders" (Avery, 2018, p. 391) and

only in this way are they able to live forever.

The spherons serve each other and to all together by producing an appropriate, necessary resource for everyone, that makes their social structure an invariant norm, a universal law of life, love, peace, nonviolence, stability and prosperity of every society. But this eternal law of social life acts stochastically, thermodynamically through historically transient partial groups of the population - partons and individuals, whose entropy is overcome only by the negentropy of the absolute social structure of spherons (Semashko et al., 2017).

Amitai Etzioni proposed two criteria for assessing the contribution of different structures and organizations to the social system: the criterion of survival and the criterion of efficiency — the degree to which goals have been achieved at a given point in time (Etzioni, 1961). Spherons, their structure fully meets the first criterion and the second criterion is fully met by the partial, sectoral structures of partons, which are born, flourish and die off, completing their historical, temporary mission within their spherons.

Paraphrasing a well-known aphorism, we can say, "*God created the spherons, they did everything else in society.*"

All of the listed invariant spherical clusters: PIOT resources/components, SIOT spheres of their continuous production, SIOT spherons as actors of their production do not exist without each other. They constitute their one invariant structure in statics. It makes possible to design the sustainable development of humanity on the third path, free from confrontations, wars and violence, alternative to the traditional violent paths of both Marxism-communism and liberalism-capitalism (Covey, 2011; Giddens, 1998; Krasnov, 2019, 2020; Kurland et al., 2014; Maguire et al., 2018; Semashko et al., 2017; Siebert, 2020; The Third Way, 1999; etc.)

This structure also illustrates well the inseparability of the spheres of production as a global, noospheric infrastructure and the spherons employed in them, as their productive actors, i.e. their absolute subjects. This static model unfolds into a dynamic global model expressing the social cybernetic genome, abbreviated as SOCIONOME of humanity.

Holistic Dynamic Cybernetic Structure of Spheres and Spherons

Model-4: Sociocybernetic Genome: Socionome of Humanity

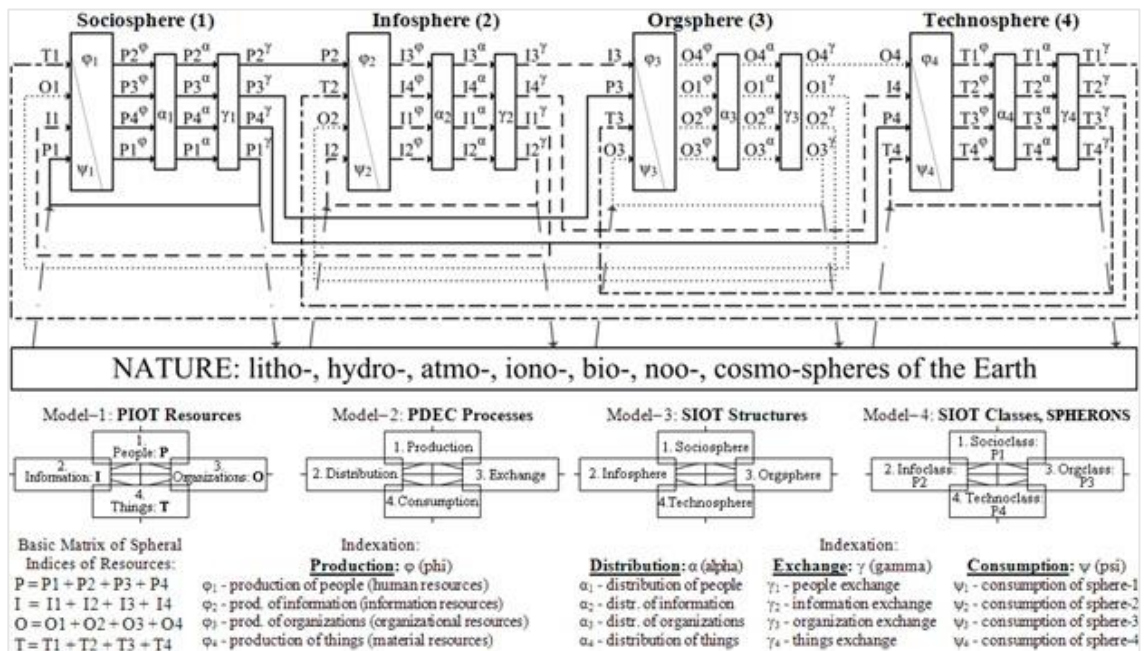

Socionome and its model have been researched since 1980 in many books and articles, the most important of which are these (Semashko, 1992, 1999, 2002, 2012, 2016, 2017, etc.).

This model illustrates well the absolute necessity and sufficiency of all 16 spherical structural cluster/elements for each other in a continuous integral social genesis, from which it is impossible to remove any of them and to which no

other can be added so as not to destroy it as a whole. Of course, the absoluteness of genetic elements in no way excludes, but necessarily presupposes, infinite knowledge of each of them, as well as their structure as a whole in all subsequent history. Only their scientific knowledge will ensure the transformation of spherons from spontaneous actors into conscious, enlightened, nonviolent actors of history, who know and are able to nonviolently

prevent and resolve all emerging conflicts and disharmony of their constituent partons. Therefore, any confrontation, war, enmity, hatred and violence are genetically excluded between the spherons, which were possible only temporarily and only between some of their partons due to their ignorance and selfishness in the early stages of human history. Therefore, peace, love, harmony and nonviolence between the spherons exist at the beginning only spontaneously, and with the advent of their science - consciously and forever in the future. (See Gandhian Global Harmony Association [GGHA] books and projects for 16 years in the bibliography).

Spherons' Historical and Empirical Confirmation

The genius author of the fundamental scientific discovery of spherons in the historical guise of the law of four equal varnas of ancient India is Mahatma Gandhi. The law of Indian varnas is the law of invariant spherons of humanity and vice versa. In it, the term "spherons" is only a modern universal synonym for varnas, which were the historical form of spherons in ancient India. Mahatma Gandhi understands well the universality

of varnas and defines their objective eternal law in the following quotations.

*Varna** [spherons**] is not a human invention, but an immutable law of nature – the statement of [genetic] tendency that is ever present and at work like *Newton's law of gravitation*. Just as the law of gravitation existed even before it was discovered, so did the law of varna [spherons]. *Varna* is the law of life universally governing the human family. This is the law of our being. All *varnas* [spherons] are equal, for the community depends no less on one than on another. Though the law of varna [spherons] is a special discovery of some Hindu seer, it has universal application. The world may ignore it today [out of ignorance] but it will have to accept it in the time to come. (Gandhi, 1955, pp. 169-172)

* Varnas are equal groups, clusters of the population of ancient India, employed in four spheres of its social production, therefore constituting its historical spherons.

**Spherons are invariant, equal groups/clusters/classes of people covering the entire population of any society in history and differing in employment in one of the four spheres of social production.

The law of equally necessity and sufficiency objective spherons in the existence of any society and humanity as a whole is as absolute, objective Newtonian law of gravitation for the natural universe that was brilliantly emphasized by Mahatma Gandhi almost a century ago. He was the first to see the "greatest force of nonviolence" of the humanity spherons, which overcomes the most powerful, nuclear violence, to which our special book (Anti-Nuclear Manifesto. 2020) is dedicated. Therefore, spherons can only bear his name as their discoverer and no one else - "Gandhian spherons".

In the 20th century, Mahatma Gandhi was not only the first to discover the "Newtonian law" of spherons of nonviolence in the historical experience of the ancient varnas but the first practically used his "greatest force of nonviolence" for the nonviolent liberation of India from the colonial slavery of Great Britain without a single shot, sacrifice and drop of blood. There is no more fundamental empirical confirmation and practical proof of the truth of this "Newtonian law" of spherons, which Gandhi tested with all his political practice of nonviolent popular (spherons) liberation of India (Gandhi, 1946, 1955, 1982, 2005).

Gandhi liberated and saved India by the spherons 70 years ago. Our task is to free and save the world from the insane suicidal confrontation of the blind partons of our time by spherons. There is no other salvation.

Another historical example of confirmation of the equal social structure of spherons is the Mycenaean civilization, discovered in Crete by Riane Eisler and other archaeologists. This civilization did not know social inequality and antagonisms, in which gender equality was a sign and reflection of the social equality of spherons, excluding any social domination (Eisler, 1994).

No less important, empirical verification of spherons in our time has been provided by their local statistical researches since 1980, and since 2005, within the framework of world statistics of 76 countries, summarized in the GGHA book "*Gandhica*" by 82 coauthors, including 4 Nobel laureates, from 25 countries (Semashko et al., 2019).

Among them, it is necessary to name professional statistical studies of spherons of different levels by the following authors, doctors and

professors: Maitreyee Roy, Subhash Chandra and Pravat Dhal in India (Semashko et al., 2019, pp. 50, 57, 63, 71). Stephen Amoah, Ayo Ayoola-Amale, Stephen Tabi and Habyarimana Heli in 6 African countries (Semashko et al., 2019, pp. 43 -48). Noor Larik, the former Director General of the Pakistan “Federal Bureau of Statistics” with a team of statisticians (Semashko et al., 2019, pp. 49, 58). Olga Kashina and Leo Semashko in Russia, Belarus and 60 countries (Semashko et al., 2019, pp. 53, 54, 72) and many others. These researches make the theory of spherons fully meet all scientific (historical, theoretical and empirical) requirements.

The most important criterion of the scientific nature of the spherons theory is a simple method of statistical verification by each literate person who owns the four actions of arithmetic, which will allow him to make sure in 2-3 hours of the spherons truth by their statistical research on any social object with available statistics: school, enterprise, university, city, branch, region, country, etc. This method in 3 pages is presented in the book "*Gandhica*" (1.4.3, pp. 34-36). Who does not believe our statistical evidence of the spherons truth over the decades;

she/he has an elementary opportunity to verify it on his own.

An important empirical confirmation of the spherons theory truth since 1975 is more than 250 pragmatic spherical projects of different social systems of different levels, the list of which is given here (Semashko, 2021).

The most important and large-scale of them is the UN global governance project in the corresponding GGHA project “Network Spherons: The UN of Harmony and Global Peace Replacing the UN of Disharmony” (Semashko et al, 2017), which was submitted to an international competition organized by the Swedish Foundation for Global Governance. The core of this project is the structural spherical model of the UN of Harmony.

Model-5. The UN General Assembly Spherical (Spherons) Structure

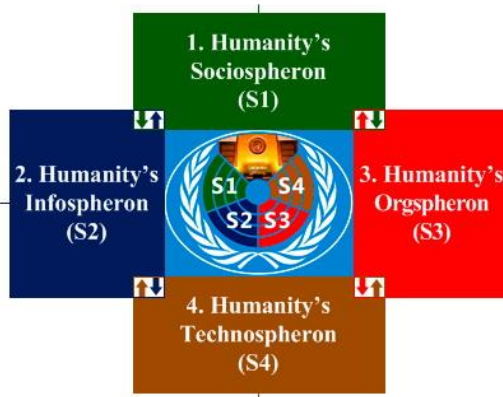

The main structural essence and advantage of this project is the formation of the UN General Assembly, uniting representatives of almost 200 member states of the UN according to the following spheral criterion. It is proposed to delegate from each of the UN 200 states to this body 8 national representatives in gender equality (4 + 4) and on 2 from each of the four spherons of each country, regardless of its size. The main thing in it is the EQUAL representation of the spherons in the global governance body. This model could become a sample for all national democracies, governments and authorities.

This model of holistic, democratic and harmonious spheral governance overcomes the main, ineradicable for millennia, vice of any power of partons, privileged parts of society. It lies in the fact that the parts power is unable to serve the interests of society as a whole, it always serves its own, partial interests, and for this purpose, it is always violent, since a part can retain power over an entire society only by violence and nothing else. Its violence, in the final analysis, always leads to the death of this particular power of a particular historical parton and a given society as a whole, the fragments of which are strewn all over

history from Adam and Eve to the present day.

Spheral Statistics, Technology, Digitalization and Spherons Internet

An unprecedented advantage of the spheral approach and the theory of spherons is a powerful toolkit of unique spheral global statistics (GlobStat) and its digital technology, which began to be created in 1980 at the “Lensystemtechnics” Project Statistical Institute. About its almost 10 years of experience see this book (Semashko, 1992).

Spheral GlobStat is an endless system of the PIOT special statistical spheral indices of a matrix fractal nature, aggregated from indices of traditional empirical statistics according to theoretical laws and recursive algorithms of the PIOT genetic social components, the PDEC processes, the SIOT spheres and the SIOT-s spherons. Therefore, it is holistic and global statistics. The absolute laws of necessity and sufficiency of the listed 16 spheral components of the socionome, which makes possible to qualitatively describe any social phenomena from the individual to humanity as a whole,

determine the equally absolute law of the necessity and sufficiency of GlobStat for their quantitative, mathematical description.

The GlobStat backbone is the statistics of PIOT spherul resources, through which the statistics of PDEC spherul processes, SIOT spherul and SIOT-s spherons are expressed. The synergistic sum of PIOT resources/components: $P + I + O + T$ expresses society in statics at any of its levels, where P (people = spherons) are the only energetic generating actors for all PIOT. Therefore, the statistics of spherons (P) is the center of GlobStat that determines peripheral / infrastructural spherul statistics. Each element/cluster of society is associated with one or another part of the spherons does not exist without them as their actors. Therefore, they all at any level can be expressed through the spherul indices of spherons, through the quantity and quality of their employment, through its time/cost/energy, disclosed in the spherul surplus value theory of spherons.

The foundation of spherul statistics is the basic 4×4 matrix of PIOT spherul indices:

$$P1 + P2 + P3 + P4 (= P)$$

$$I1 + I2 + I3 + I4 (= I)$$

$$O1 + O2 + O3 + O4 (= O)$$

$$T1 + T2 + T3 + T4 (= T)$$

On its basis, a practically infinite system of derivative detailing fractal matrices of other dimensions is built using a simple algorithm: $4 \times 4n$, where n is a series of natural numbers in modifications from +1, or from -1, or others for different states and sets of PIOT. For practical purposes, it can be limited by different levels of the description depth, for example, 4×48 , 4×416 , 4×464 , 4×4256 , etc. Numerous theoretical developments of spherul statistics, its mathematics and digital technologies are presented in many books (Semashko, 1992). Therefore, we will restrict ourselves here only to conclusions.

The pragmatic social meanings outline of spherul statistics, together with its digital information technology, is presented as follows:

1. Innovative spherul GlobStat is becoming a fundamental and adequate mathematical tool for spherul thinking, providing a qualitatively new level of digitalization, Information Technology, Internet, Artificial Intelligence, Big Data, etc.

2. GlobStat provides, in the future of our century, the creation of millions of new highly intelligent jobs for the innovative information infrastructure of humanity, a new intelligent inexhaustible business comparable in terms of its effective scale with the hydrocarbon business. It will replace it and transforming the infosphere into the leading population class in terms of value and size due to the robotization of the technosphere, reduction of technosphere, its retraining and overflowing into infosphere.
3. GlobStat, its digitalization and mathematics are a fundamentally new strategic source of national and global wealth for the entire future of a spherical harmonious and nonviolent civilization.
4. GlobStat, its digitalization and mathematics is a fundamentally new strategic way and unprecedented tool of national and global security, global peace, nonviolence, prosperity and sustainable development of humanity on the planet with the possibility and ability to resolve all traditional unsolvable challenges and prevent all emerging conflicts (Semashko, 2020).
5. GlobStat, its digitalization and mathematics is a digital harmonious breakthrough of the human mind from the era of violence to the era of nonviolence in the 21st century.
6. GlobStat, its digitalization and mathematics provide an information platform for a new, nonviolent democracy as a complete democracy, excluding war, violence, militarism and the arms race in the 21st century.
7. GlobStat, its digitalization and mathematics determine the only cardinal way to solve the global environmental problem: overcoming warming and establishing a harmonious and sustainable spherical balance between nature and humanity through control and global management of interactions between their spheres.
8. GlobStat, its digitalization and mathematics open up the production of a practically unlimited class of individual applications of various types and purposes for smartphones. Their production creates a fundamentally new and innovative market of digital spherical gadgets, unlimited in time, demand and

diversity, which infinitely pays off any initial investment in it.

survival, global peace and sustainable development (Maguire et al., 2018).

9. The highest level of production efficiency, labor productivity and sustainability of any collective: family, government, parliament, equipage, organization and any team: manufacturing, governing, scientific, educational, sports, medical and the like depends from the spheral compatibility of its members, which is determined by the internal consent, harmony of its spherons, balance of distribution of resources and functions between their members. The measure of their compatibility, consistency and effectiveness is monitored and controlled by spheral statistics in the corresponding spheral methods/technique, which began to be created and used since 1989 (Semashko, 1992, p. 334).

10. The toolkit of spheral GlobStat allows humanity to master the "Newtonian law" of the spherons in the social universe and their "greatest force, energy of nonviolence, mightier than the mightiest destructive nuclear weapon" (Gandhi), still unknown to it and not used by it to eradicate confrontation, hostility, violence and to erase its

Conclusion

Summing up our integral sociological article, we must emphasize that scientific knowledge and the use of the theoretical hypothesis of spherons as a genetic social structure provides enlightened in it humanity the genesis of a conscious nonviolent future without confrontation and violence. This is the only way to save every nation and humanity as a whole. Which country will become its leader in order to replace the traditional false norm of pathological and suicidal violence with the norm of the highest viability of nonviolence spherons (Tolstoyevskaya, 2020)?

Together with the cardinal transformation of social science and democratic power, together with the formation of an integral harmonious worldview and the corresponding global education of new generations, business and competition are qualitatively changing. Based on the scientific social structure of spherons and their democracy, they acquire a holistic, harmonious, nonviolent, humanistic and peacemaking character, freeing themselves from the traditional vices of selfishness, avidity, narrowness, violence, cruelty and greed. Any fundamental science generates its own big global business. And if it is not in the

humanitarian field, then this signifies only one thing: the absence of fundamental socio-humanitarian science, which appears on the basis of nonviolent genetic spherons. The fundamental spherons science, together with its unprecedented tools and technologies, opens up a fundamentally new global business in terms of content, efficiency, rules, priorities, values and ethics.

Purposeful strategic development of this science, integrating all constructive ideas, is possible only in the open International Humanitarian Academy/Laboratory of Spherons (IHAS), for a start, from 10-15 humanities scientists, statisticians, mathematicians and programmers. They require only about \$ 500,000 for the first year, which will pay off in the second year. All this can be cut in half for the first year. A country that today will be able to understand the global need for IHAS and finance it will become a world technological, intellectual and business leader during 4-7 years. It will allow to exclude the 100% prepared nuclear suicide, genocide and ecocide today (Avery, 2017a, 2017b; Maguire et al., 2018).

The responsible humanitarians, primarily from the GGHA, who have mastered the scientific alphabet of spherons during 16 years, need to do everything possible to establish the IHAS wherever possible. Our article is

its common starting scientific platform, direct access to a new, spherical technological, intellectual and business bifurcation to the genesis of a conscious harmonious future as the Rubicon of no return to the traditional era of violence and confrontation.

Disclosure Statement

The authors declare that no potential conflict of interest exists.

References

- Ashby, W. (1956). *An introduction to cybernetics*. Chapman and Hall.
- Avery, J. (2017a). *Nuclear weapons: An absolute evil, genocide and crime against humanity*.
<https://bit.ly/3nspWWb>
- Avery, J. (2017b). *The climate emergency two time scales*.
www.lulu.com
- Avery, J. (2018). *The information explosion*. www.lulu.com
- Barulin, B. (1982). *Dialectics of the spheres of social development*.
- Bentler, P. (2010) *Structural modeling: History, applications and opportunities*. <https://bit.ly/3ys2pdh>
- Bertalanffy, L. von. (1962). General system theory – A critical review. *General Systems*, 7, 1–20.

- Bogdanov, A. (1922). *Tectology – General organizational science*.
- Braudel, F. (1988). *Exchange games*.
- Castells, M. (2000). *The information age: Economy, society and culture*. Wiley Blackwell.
- Covey, S. R. (2011). *The 3rd alternative*. Free Press.
- Eisler, R. (1994). *The chalice and the blade*. Harper Collins.
- Etzioni, A. (1961). *A comparative analysis of complex organizations*. Free Press
- Gandhi, M. (2005). All men are brothers. A&C Black.
- Gandhi, M. (1946). *My life is my message*. <https://bit.ly/3yvGPpo>
- Gandhi, M. (1955). *My religion*. <https://bit.ly/3Agb0lC>
- Gandhi, M. (1982). *On nuclear arms*. <https://bit.ly/3ApFaTo>
- Giddens, A. (1984). *The constitution of society. Outline of the theory of structuration*. Polity Press.
- Giddens, A. (1998). *The third way: The renewal of social democracy*. Polity Press.
- Hartley, R.V.L. (1928). Transmission of information. *Bell System Technical Journal*, 535–563.
- Kant, I. (2003). Perpetual peace: A philosophical sketch. Hackett Publishing Company.
- Kondratyev, N. (1930). *Basic problems of economic statics and dynamics*.
- Krasnov, V. (2019). Mahatma Gandhi and Aleksandr Solzhenitsyn: The two giants who blessed the 21st century. <https://bit.ly/3y71Ips>
- Krasnov, V. (2020). *From the East to the West. A message of peace*. <https://bit.ly/3a4Skux>
- Kurland, N., Brohawn, D., & Greaney, M. (2014). *The just third way. How we can create green growth, widespread prosperity and global peace*. Center for Economic and Social Justice.
- Lozansky, E. (2021). Lead not by force, but by example – about the new declared tasks in US foreign. <https://bit.ly/3yAeRZH>
- Luhmann, N. (2007). *Introduction to systems theory*. Publishing House.
- Maguire M., Avery J., & Semashko, L. (2018). US-Russia summit. The great peace charter XXI. <https://bit.ly/3l6mPN1>
- Marx, K., & Engels, F. (1956). *German ideology*. GPPL.
- Maturana, H., & Varela, F. (1980). Autopoiesis: The organization of the living. *Autopoiesis and Cognition*, 63–134.
- Parsons, T. (1977). The present status of ‘structural-functional’ theory in sociology. In *Social systems and the*

- evolution of action theory* (pp. 100–117). Free Press.
- Parsons, T. (2007). *American society: A theory of societal community*. Paradigm Publishers.
- Prigogine, I., & Stengers, I. (1984). *Order out of chaos: Man's new dialogue with nature*. Flamingo.
- Semashko et al., (2020). *Anti-nuclear manifesto XXI*. Licorne International.
- Semashko, L. (1992). *Spherical approach*. Notabene.
<https://bit.ly/3AibB6s>
- Semashko, L. (1999). *Sociology for pragmatists*. <https://bit.ly/3Af8NXJ>
- Semashko, L. (2002). *Tetrasociology: Responses to challenges*. St. Petersburg State Polytechnic University. <https://bit.ly/3Aihn7S>
- Semashko, L. (2012). *The ABC of harmony as sociocybernetics of the third order*. <https://bit.ly/3AjMtfw>
- Semashko, L. (2017). *Deep social structure of SPHERONS' harmony: Copernican revolution of sociology in the XXI century*.
<https://bit.ly/3Aiyg2z>
- Semashko, L. et al. (2016). *Global peace science*.
<https://bit.ly/3bG8v1A>
- Semashko, L. et al. (2019). *Mahatma Gandhi. Nonviolence starting point. Spherons' genome and statistics*.
<https://bit.ly/3ntmXN4>
- Shannon, C. E. (1948). A mathematical theory of communication. *Bell System Technical Journal*, 27, 379–423.
- Siebert, R. (2020). The third way.
https://peacefromharmony.org/?cat=en_c&key=945
- Sloterdijk, P. (1998). *Sphären I – Blasen, Mikrosphärologie*. Suhrkamp Verlag.
- Sloterdijk, P. (1999). *Sphären II – Globen, Makrosphärologie*. Suhrkamp Verlag.
- Sloterdijk, P. (2004). *Sphären III – Schäume, Plurale Sphärologie*. Suhrkamp Verlag.
- Firth, M. (1904). *The golden verses of Pythagoras*. <https://www.sacred-texts.com/cla/gvp/index.htm>
- The Third Way. (1999). *Progressive governance for the 21st century*. The White House.
- Toffler, A. (1980). *The third wave: The classic study of tomorrow*. Bantam.
- Tolstoyevskaya, A. (2020). *When pathology becomes the norm*.
https://peacefromharmony.org/?cat=en_c&key=978

Authors' Biosketch

Bishnu Pathak, a former Senior Commissioner at the Commission of Investigation on Enforced Disappeared Persons (CIEDP) in Nepal, has been nominated for the Nobel Peace Prize from 2013 to 2019 for his discovery of the Peace–Conflict Lifecycle which he compares to an ecosystem. Dr. Pathak is a Board Member of the TRANSCEND Peace University and holds a Ph.D. in interdisciplinary Conflict Transformation and Human Rights, earned over two decades in 2003. Despite the challenges, Professor Pathak has authored over 100 international books and papers, including “Politics of People’s War and Human Rights in Nepal” (2005), “Generations of Transitional Justice in the World” (2019), “The Nepal Compact: Potential for Cold War II” (2022), “Negotiation by Peaceful Means: Nepo-India Territorial Disputes” (2022), and “The Arts of Eastern Philosophy” (2023). Many of his publications have been used as references in universities in over 100 countries worldwide. Dr. Pathak’s work covers a wide range of topics, including Transitional Justice, Human Rights, Human Security, Peace, and Conflict Transformation. Web: https://peacefromharmony.org/?cat=en_c&key=910

Mairead Corrigan Maguire is a peace activist from Northern Ireland and a co-recipient of the Nobel Peace Prize with Betty Williams in 1976 for their work as co-founders of the Women for Peace, which later became the Community for Peace People, an organization dedicated to encouraging a peaceful resolution to violence in Northern Ireland. Web: https://peacefromharmony.org/?cat=en_c&key=678

John Scales Avery (1933-2024), a 1995 Nobel Peace Prize Laureate, is a Professor Emeritus at the University of Copenhagen, Denmark. He is noted for his books and research publications in quantum chemistry, thermodynamics, evolution, and history of science. Since 1990 he has been the Chairman of the Danish National Group of Pugwash Conferences on Science and World Affairs. Between 2004 and 2015, he also served as Chairman of the Danish Peace Academy. Web: https://peacefromharmony.org/?cat=en_c&key=672

Semashko Leo Mikhailovich is a Russian visionary, philosopher, sociologist, author and peacemaker. He is the founder and president of the international peacemaking organization Global Harmony Association (GHA) and an honorary member of RC51, Sociocybernetics, International Sociological Association. His more than 600 scientific publications, including 18 books, focus on his discovery and development of scientific theories of tetraphilosophy, global sociology and harmonious civilization. He is the discoverer of spherons, Tetrasociology or third order Sociocybernetics, Tetrapyschology, spherical statistics and global peace science. Web: https://peacefromharmony.org/?cat=en_c&key=253

To cite this article: Pathak, B., Maguire, M. C., Avery, J. S., & Semashko, M. L. (2022). Gandhian spherons: India/Nepal return to the varnas peace world leadership. *Social Inquiry: Journal of Social Science Research*, 4, 24-49. <https://doi.org/10.3126/sijssr.v4i1.64805>
